

3 Point Seat Belt Shoulder Anchor Point Installation Door Post Extends to Roof

Step by step instructions, and diagrams for retrofitting Wesco 3 point seat belts by creating a shoulder mounting point using our #10154 mounting plate for your older automobile, classic car, vintage car, kustom kar, hotrod etc.

These shoulder anchor point retrofitting instructions to be used only for WESCO Seatbelts.

These instructions are NOT to be used for 3 point seat belts for sale from other manufacturers or retailers. **CAUTION:** Read these instructions for retrofitting seatbelts thoroughly before beginning the retrofitting process and installing the safety harness.

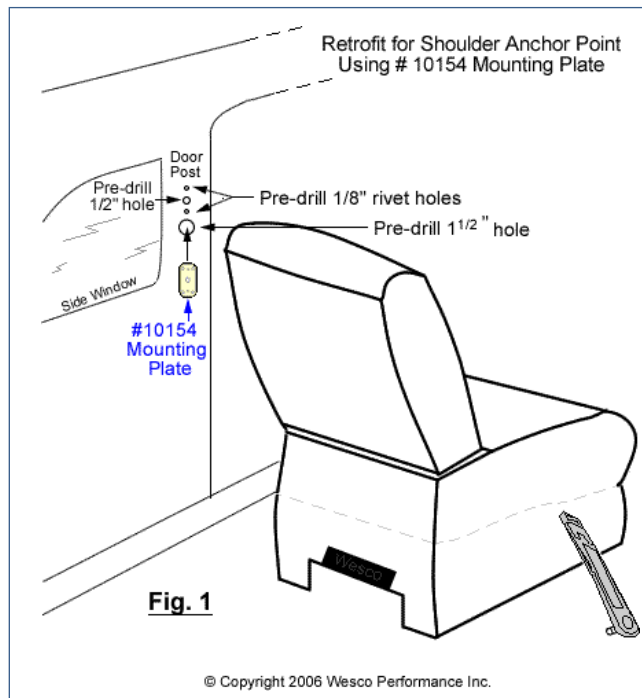

Step # 1: Prepare the work area. If your vehicle has upholstered or plastic panels that cover the retrofitting area, remove them to expose the bare metal.

Step # 2: Determine the location. Next determine the exact location for the new shoulder bolt anchor point (preferably at or 0-8 inches above the top of the seat back and slightly to the rear of the seat back). The user assumes the risk of choosing a safe location for the anchor point. The effectiveness of this equipment is directly related to the manner in which it is installed, used, and/or maintained. Proper installation is solely the responsibility of the installer, and will not be assumed by WescoPerformance.com.

Step # 3: Mark for drilling. Using the #10154 mounting plate as a template, hold the mounting plate up against the outside of the door post (vertical long ways) at the exact position that you want to install the shoulder bolt anchor point. (**Note:** Some applications the anchor point will be retrofitted above the side window.) Mark the door post metal by outlining the middle 7/16" hole and the 2 smaller 1/8" holes that are above and below the center hole in the midline of the plate. Also mark along the bottom edge of the #10154 mounting plate. Place a mark 1" straight down from the center of the lined marked at the bottom of the plate.

Step # 4: Center punch & Drill the necessary holes. Using a center punch, tap a dent in the center of each marked hole and also at the mark that was placed 1" below the line which was marked at the bottom of the plate. (Center punching will act as a guide by helping to keep your drill bit from moving while drilling.) Next, as seen in [Fig. 1](#), use a 1/2" drill bit and drill the center hole. Then use a 1/8" drill bit to drill the 2 smaller holes that are to be located above and below the center hole. For the last hole that you marked and center punched 1" below the bottom of the plate, you will need to drill it with a 1 1/2" boring drill bit.

Step # 5: Insert plate and rivet into place. As seen below in Fig. 2, slide the #10154 plate through the 1 1/2" hole up into the inner wall of your vehicle. Line up the pre-drilled holes with the corresponding holes on the mounting plate and hold in position. Then using 1/8" rivets that have a 3/8" shank (reach), insert a rivet into each one of the 2 pre-drilled 1/8" holes and then into the corresponding holes on the mounting plate and rivet into place.

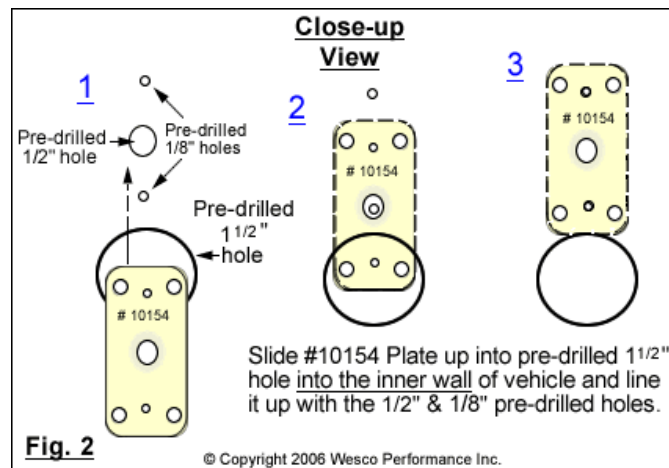

Step # 6: Finishing work. Now that the new retrofitted shoulder anchor point for your 3 point seat belt is completed and in place, you can begin the task of doing the finishing work. (Making the mounting area look good again.) If you have removed a panel to do the retrofitting, then you will need to drill a 1/2" hole in it. Carefully determine where to drill the hole in the panel, so that when the panel is re-installed, the hole will line up properly with the 1/2" hole that you drilled into the vehicle's side wall. This will be the hole in which the 3 point seat belt's shoulder bolt will be inserted.

If you have just painted metal, so you did not have a panel to remove, then you should be able to purchase a 1 1/2" plastic or metal plug (cap) that you can snap into place to cover the hole. The plastic ones can usually be purchased in different colors and the metal ones can be painted to match your vehicle. You should be able to purchase these at your local hardware store in the electrical or plumbing departments. We purposely chose to drill the 1 1/2" hole below the resting place for the plate, so that once your 3 point seat belts are installed, the seat belt webbing (straps/belts) will cover the 1 1/2" hole or cap and therefore help hide the area.

That's it! You are now ready to install your new seat belts!

Disclaimer. Please read: These instructions are supplied without warranty expressed or implied. No warranty or representation is made as to the product's ability to protect the user from any injury or death in any manner of use. The user assumes that risk. The effectiveness of this equipment is directly related to the manner in which it is installed, used, and/or maintained. Proper installation is solely the responsibility of the installer, and will not be assumed by *Wesco Performance Inc.*